

Reduced Switch Count Photo Voltaic Array Integrated Novel Multi Level Inverter Topology

Nitesh Prakash¹ and Prerna Gaur²

^{1,2}Instrumentation and Control Engineering Department,

Netaji Subhas University of Technology, New Delhi

E-mail: ¹prakash.nitesh993@gmail.com, ²prernagaur@yahoo.com

Abstract—In this paper novel multi level inverter topology with reduced switch count is proposed with photo voltaic array as DC source connected to the inverter. A 25 level AC voltage is generated with only eight unidirectional switches and two bidirectional switches with reduced harmonics in the voltage. The total number of DC sources are four, with two sources at voltage level V_{dc} and two source at voltage level $5V_{dc}$. The DC source considered is PVA which is connected to booster converter controlled by voltage oriented control for stable DC voltage generation. The 25 level output voltage from the inverter is generated by specific switching pattern for the power electronic switches. The complete multilevel inverter topology along with PVA booster converter modules are modeled and analyzed using MATLAB/Simulink software. The harmonic analysis of the voltage and current for different operating conditions is done using FFT analysis tool available ‘powergui’ toolbox.

Keywords: PVA (Photo Voltaic Array), MATLAB (Matrix Laboratory), FFT (Fast Fourier Transformation), POWERGUI (Power Graphical User Interface).

I. INTRODUCTION

Utilization of renewable sources in modern power systems is very crucial as they do not produce any hazardous gases or waste which pollutes the environment. Renewable source [1] use natural source like solar insolation, wind, bio gas, ocean tides for generation of electrical power. Different renewable sources that are available with present technology are solar plants, wind farms, natural gas plants, tidal wave energy plants etc. From all these renewable sources solar plants [2] are considered as optimal option for generation of power from solar insolation. This renewable source of power generation is very easy for installation, as the solar panels can be placed in any area or location with less capital cost as compared to other renewable sources. The controllers for the operation of solar plants are also less complex and hence the maintenance is also economic. Expansion of solar module in order to increase the power generation output from the plant is also less complicated. Hence larger percentage of renewable source installations throughout the world is solar plants.

Power from PVA modules cannot be consumed by the loads as the voltage generated from the PVA modules is

in DC and most of the loads in power systems are AC. The DC voltage of the PVA module [3] needs to be converted to AC using inverter circuit topology. Even the DC voltage from the PVA module is also not constant and hence DC-DC converter modules are used for constant DC voltage stabilization. There are many conventional inverter topologies which include six switch voltage source inverter, neutral point inverter [4] [5] [9] which have less number of levels. Lower number of levels in the output voltage creates harmonics in the load currents and may damage the devices.

Therefore, multilevel inverters [6] must be used for higher number of voltage levels [10] in the output which reduces harmonics in the load current and the reliability of the devices increase. Conventional topologies like cascaded multilevel inverters, diode clamped multilevel inverters, Flying capacitor multilevel inverters [7] have very high number of switches which increase switching losses and the efficiency of the converter drops [8]. Therefore, better inverter topologies need to be introduced with higher number level outputs and reduced number of switches for increased efficiency. In previous researches [4] [5] different multi level inverters with reduced switch count for reduction of switching losses are introduced. In most of the inverters the number of level are less in range of seven and nine levels. Lower levels lead to higher harmonic distortions even though there are less losses. Therefore, better inverter circuit topologies are needed with less number of switches and also increased number of levels in range of 15 to 25 levels. In this paper a novel multilevel inverter topology is proposed with less number of switches. The proposed topology can be seen in figure 1.

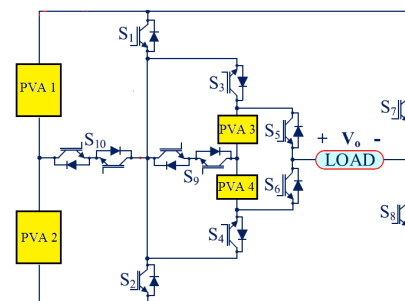

Fig. 1: Proposed 25 Level Multilevel Inverter Topology

In this paper section I is the introduction of the proposed 25 level multilevel inverter topology followed by section II which includes configuration and operating states of the proposed circuit. The section III discusses about the stabilization of output DC voltage of PVA module. Simulation results and outputs of the proposed topology are discussed in section IV followed by final section V with conclusion to the paper and references used for modeling of the circuit.

II. PROPOSED TOPOLOGY CONFIGURATION

The 25 level multilevel inverter topology [11] is proposed in figure 1 which has four DC sources replaced by photovoltaic array as sources. The PVA module is combination of multiple panels connected in parallel and series which generates specific power at given rated voltage. The four PVA modules are asymmetrical as the voltage magnitudes [12] are different for the PVA modules. As previously mentioned the PVA1 and PVA2 modules are specified with Vdc voltage, PVA3 and PVA4 are

specified with 5Vdc voltage. As seen in figure 1 proposed topology the converter has only ten switches [13], which include eight unidirectional IGBT switches (S1-S8) and two bidirectional back to back connected IGBT switches (S9 and S10). There are four PVA modules connected with PVA1 PVA2 modules operating at DC voltage Vdc and the PVA3 PVA4 modules operating at 5Vdc voltage magnitude.

The switching states for generation of different voltage levels in order to create 25 level output voltage is given in table 1.

With the above switching states [14] fed to the switches a sinusoidal waveform is created raising the voltage from zero level to +12Vdc and dropping back to zero in steps creating positive voltage. For negative side voltage, the voltage is raised in negative direction from zero to -12Vdc and dropped back to zero. This continuous creation of positive and negative waveforms represents sinusoidal voltage waveforms. The expected voltage levels are shown below in figure 2.

TABLE 1: SWITCHING STATES OF SWITCHES FOR MULTI LEVEL VOLTAGES

S1	S2	S3	S4	S5	S6	S7	S8	S9	S10	Vout
0	1	1	0	0	1	0	1	0	0	-12Vdc
0	0	1	0	0	1	1	0	0	1	-11Vdc
0	1	1	0	0	1	0	1	0	0	-10Vdc
0	0	1	0	0	1	0	1	0	1	-9Vdc
1	0	1	0	0	1	0	1	0	0	-8Vdc
0	1	0	0	0	1	1	0	1	0	-7Vdc
0	0	0	0	0	1	1	0	1	1	-6Vdc
0	1	0	0	0	1	0	1	1	0	-5Vdc
0	0	0	0	0	1	0	1	1	1	-4Vdc
1	0	0	0	0	1	0	1	1	0	-3Vdc
0	1	0	1	0	1	1	0	0	0	-2Vdc
0	0	0	1	0	1	0	1	0	1	-Vdc
1	0	1	0	1	0	1	0	0	0	0
0	0	1	0	1	0	0	1	0	1	Vdc
1	0	1	0	1	0	0	1	0	0	2Vdc
0	1	0	0	1	0	1	0	1	0	3Vdc
0	0	0	0	1	0	1	0	1	1	4Vdc
1	0	0	0	1	0	1	0	1	0	5Vdc
0	0	0	0	1	0	0	1	1	1	6Vdc
1	0	0	0	1	0	0	1	1	0	7Vdc
0	1	0	1	1	0	1	0	0	0	8Vdc
0	0	0	1	1	0	1	0	0	1	9Vdc
1	0	0	1	1	0	1	0	0	0	10Vdc
0	0	0	1	1	0	0	1	0	1	11Vdc
1	0	0	1	1	0	0	1	0	0	12Vdc

III. PVA MODULE MODELING

The DC sources in the proposed 25 level multi level converter are integrated with PVA modules which have PV panel connected to DC-DC booster converter [2]. The panels do not generate stable voltage, the magnitude of the voltage changes with respect solar insolation. Hence to stabilize the voltage a DC-DC booster converter is used with voltage feedback oriented control. The booster converter maintains the input voltage to the inverter at a specific given reference value. The PV module with PV panel and DC-DC booster converter [3] can be seen in figure 3 below.

In the above given topology the PV panel rating is given as per table 2. With the above parameters one panel is connected to the booster converter which increases the voltage to 30V. The reference voltage of PVA1 and PVA2 modules are given as 30V as per our requirement. Therefore $V_{dc} = 30V$ is one level voltage at the output of the inverter. Therefore, the PVA3 and PVA4 modules

reference has to be $5V_{dc} = 150V$, hence five panels are connected in series in PVA3 and PVA4 modules. The voltage feedback oriented control for controlling the booster converter can be seen in figure 4 below.

As per the controller the reference DC voltage value V_{dc}^* is compared to measured DC voltage V_{dc} at the output terminals of the booster converter. The error is fed to voltage controller which is PI controller with tuned K_p (Proportional gain) and K_i (Integral gain) values. The output of the PI controlled is duty ratio which is compared to high frequency PWM generator. The PWM generator is high frequency saw tooth waveform comparison to duty ratio for generation of pulse to IGBT switch of the booster converter. With the above circuit topologies and controller the output voltage of PVA1 PVA2 modules are fixed at 30V and the output voltages of the PVA3 PVA4 modules are fixed at 150V. The simulation results and output graphs are generated for the given modules in the next section.

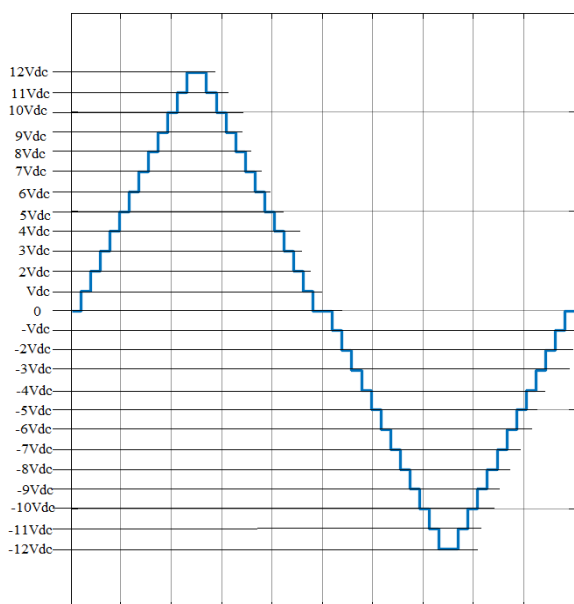

Fig. 2: 25 Level Voltages Output as per Switching Given by Table I

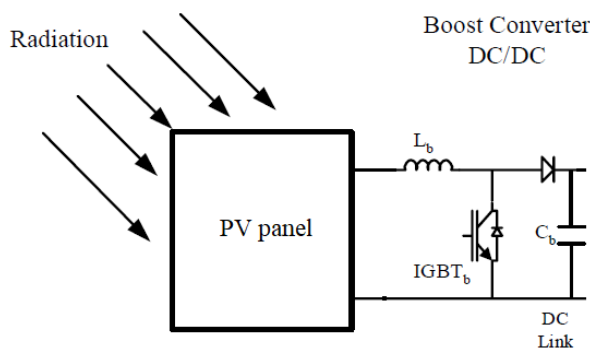

Fig. 3: PV Module Circuit Diagram

TABLE 2. PV PANEL PARAMETERS

Name of the parameter	Value
Voltage at maximum power V_{mp}	17.1V
Current at maximum power I_{mp}	3.5A
Open circuit voltage V_{oc}	21.1V
Short circuit current I_{sc}	3.8A
Maximum power P_{mp}	60W

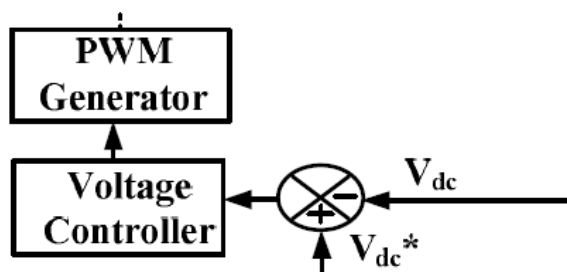

Fig. 4: Voltage Feedback Oriented Control

IV. SIMULATION RESULTS AND DISCUSSION

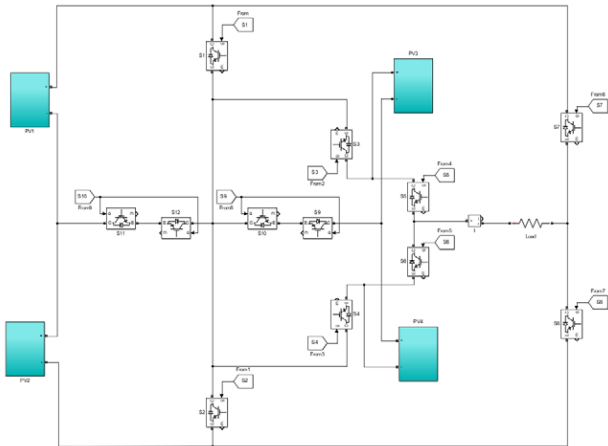

Fig. 5: Simulation Design of the Proposed 25 Level Multi Level Topology

The above figure 5 is the Simulink modeling in MATLAB software of the proposed 25 levels inverter topology with PVA modules as DC sources. The internal modeling of the PVA module with PV panels and DC-DC booster converter controlled by voltage feedback oriented control is shown in figure 6 below.

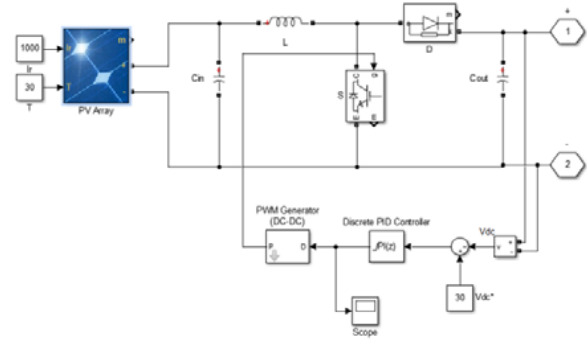

Figure 6: PVA Module Circuit Topology

The above complete circuit topology is run for simulation time of 0.1sec and the results are recorded with respect to time. The below are the output voltage and current of the load connected to the 25level inverter topology.

The pulses for the switches S1-S10 generated as per table I for one cycle of frequency with 50Hz is shown in figure 8.

The FFT analysis of the output voltage with 25levels to determine the THD (Total Harmonic Distortion) of the voltage can be seen below.

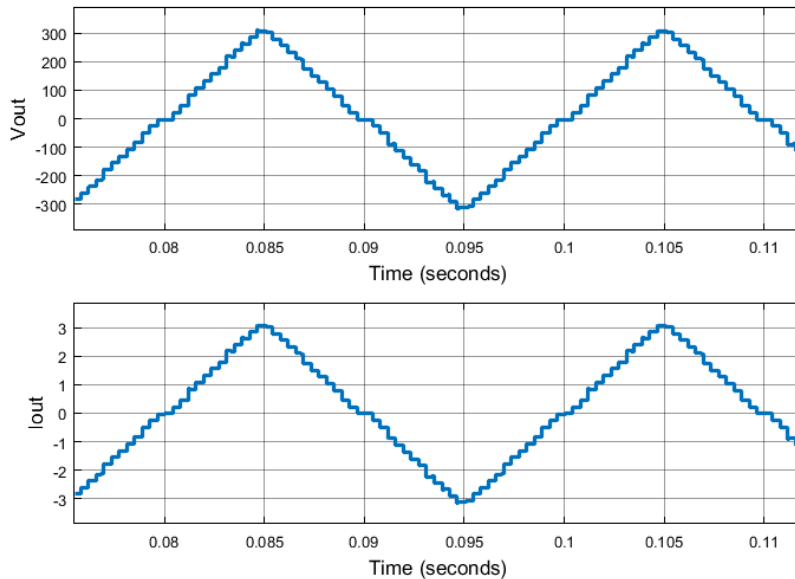

Fig. 7: Output Voltage and Current

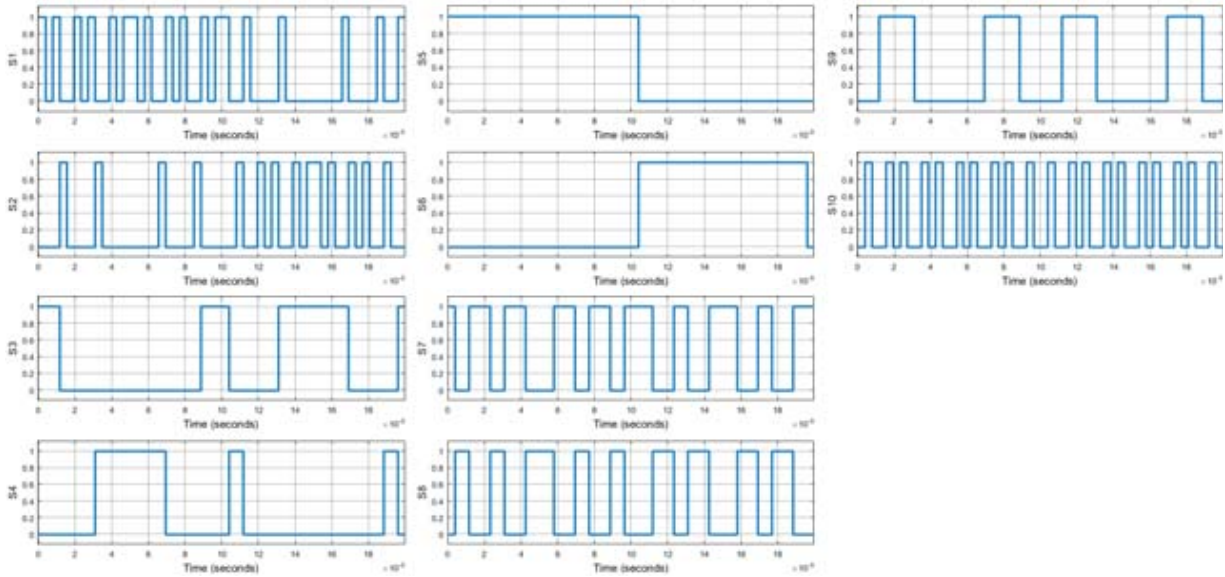

Fig. 8: Pulses for S1-S10 Switches

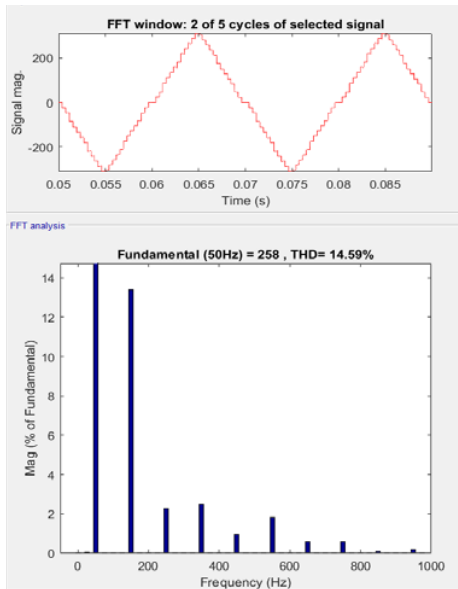

Fig. 9: THD of the Output Voltage with 25 Levels

V. CONCLUSION

As per the given results successful implementation of 25level multi level inverter topology is done and is shown in section IV. The conventional battery DC sources are replaced with PVA modules with different voltage levels for the generation of the required voltage. For DC voltage stabilization of PV panel output booster converter is operated with voltage feedback oriented controller. The output voltage of the inverter is analyzed using FFT analysis tool available in powergui toolbox with THD recorded at 14.59%. The harmonics in the output voltage are very less with reduce switch count and the inverter is operated with PVA renewable source.

REFERENCES

- [01] D. Hansen et. al. , " Models for a Stand-alone PV System", Ris National Laboratory, Roskilde, Norway, Dec. 2000.
- [02] Altas. I, A. M. Sharaf, 2007 "A photovoltaic array (PVA) simulation model to use in Matlab Simulink GUI environment." IEEE I-4244- 0632 -03/07.
- [03] Weidon Xiao, 2004 "A novel modeling method for photovoltaic cells" 2004, 35th annual IEEE power electronic specialist conference.
- [04] Jose Rodriguez, Jin-Sheng Lai and Fang Zheng, "Multilevel Inverters: A survey of topologies, Control applications," IEEE transactions on Industrial Electronics, Vol.49, No. 4, pp. 724-738, August 2002.
- [05] J. Rodriguez, S. Bernet, P. K. Steimer, and I. E. Lizama, "A survey on neutral-point-clamped inverters," IEEE Trans. Ind. Electron., vol. 57, no. 7, pp. 2219–2230, Jul. 2010.
- [06] E. Babaei, S. H. Hosseini, G. B. Gharehpetian, M. T. Haque, and M. Sabahi, "Reduction of dc voltage sources and switches in asymmetrical multilevel converters using a novel topology," Elsevier J. Electr. Power Syst. Res., vol. 77, no. 8, pp. 1073–1085, Jun. 2007.
- [07] Z. Du, L. M. Tolbert, J. N. Chiasson, and B. Ozpineci, "A cascade multi-level inverter using a single dc power source," in Proc. IEEE APEC, 2006, pp. 426–430.
- [08] B. A. Welchko, "A three-level MOSFET inverter for low-power drives," IEEE Trans. Ind. Electron., vol. 51, no. 3, pp. 669–674, Jun. 2004.
- [09] N. Hatti, Y. Kondo, and H. Akagi, "Five-level diode-clamped PWM converters connected back-to-back for motor drives," IEEE Trans. Ind. Appl., vol. 44, no. 4, pp. 1268–1276, Jul./Aug. 2008.
- [10] H. Akagi, "Multilevel converters: Fundamental circuits and systems," Proc. IEEE, vol. 105, no. 11, pp. 2048–2065, Nov. 2017.
- [11] K. K. Gupta, A. Ranjan, P. Bhatnagar, L. K. Sahu, and S. Jain, "Multilevel inverter topologies with reduced device count: A review," IEEE Trans. Power Electron.,

- vol. 31, no. 1, pp. 135–151, Jan. 2016.
- [12] E. Samadaei, S. A. Gholamian, A. Sheikholeslami, and J. Adabi, “An envelope type (E-type) module: Asymmetric multilevel inverters with reduced components,” *IEEE Trans. Ind. Electron.*, vol. 63, no. 11, pp. 7148–7156, Nov. 2016.
- [13] M. Jayabalan, B. Jeevarathinam, and T. Sandirasegarane, “Reduced switch count pulse width modulated multilevel inverter,” *IET Power Electron.*, vol. 10, no. 1, pp. 10–17, Jan. 2017.
- [14] G. Konstantinou, J. Pou, S. Ceballos, R. Darus, and V. G. Agelidis, “Switching frequency analysis of staircase-modulated modular multilevel converters and equivalent PWM techniques,” *IEEE Trans. Power Del.*, vol. 31, no. 1, pp. 28–36, Feb. 2016.